

FLOORS, INTERIOR

Crack Isolation Membrane

Partial Coverage

F125-07

Recommended Uses:

- wherever crack isolation is required over existing in-plane cracks.
- see NOTE on page 19 for exterior uses.
- for protection against future in-plane cracking, full-coverage is recommended and must be additionally specified (F125A).

Limitations:

- not recommended for severe chemical exposure. Confirm with membrane manufacturer.
- for lateral (in-plane) movement only.
- deflection not to exceed 1/360 of span. (Deleted 2007, see Requirements.)

Requirements:

- floor systems over which tile will be installed shall be in conformance with the IRC for residential applications, the IBC for commercial applications, or applicable building codes. See Page 12 for load considerations.
- for existing cracks, soft joints may be required adjacent to cracks per manufacturer's instructions.
- specifier to identify areas of coverage.

Materials:

- crack isolation membrane—ANSI A118.12.
- latex-portland cement mortar—ANSI A118.4.
- grout—ANSI A118.3, A118.6, A118.7, or A118.8.
- sealant complying with ASTM C920.

Preparation by Other Trades:

- maximum variation in subfloor—1/4" in 10'-0" and 1/16" in 1'-0" from the required plane.

Preparation by Tile Trade:

- crack isolation membrane—install to comply with manufacturer's directions.

Installation Specifications:

- tile—ANSI A108.5.
- crack isolation membrane—ANSI A108.17 or follow manufacturer's recommendations.

Movement Joint (architect must specify type of joint and show location and details on drawings):

- movement joints—mandatory according to Method EJ171, page 79.

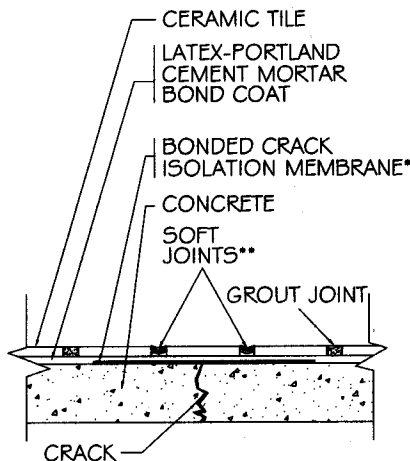

*CONSULT MANUFACTURER FOR MEMBRANE WIDTH

**ONE OR TWO SOFT JOINTS MAY BE REQUIRED (CONSULT MANUFACTURER)

Full Coverage

F125A-07

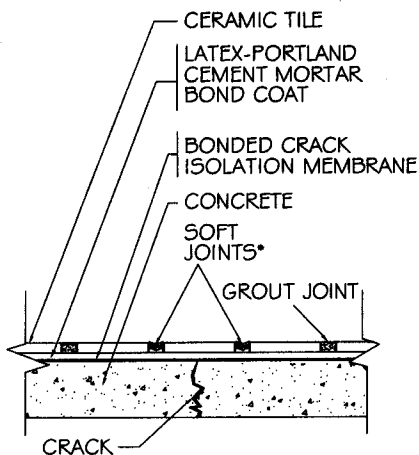

*ONE OR TWO SOFT JOINTS MAY BE REQUIRED (CONSULT MANUFACTURER)

All specifications for ceramic tile installations must conform to local building codes, ordinances, trade practices, and climatic conditions.

Not all methods are suitable for glass tile installations. Consult glass tile manufacturer for specific recommendations.

Consult