

### How to use a Hydrometer:

1. Pour your FireFighter GL into the "Hydrometer Jar" that is dry or well rinsed with a portion of the sample.
2. Make sure your sample is thoroughly mixed before testing.
3. Immerse the Hydrometer in the liquid to a point slightly below the location where it naturally floats. Make sure the Hydrometer and liquid are at rest and free of air bubbles.
4. Measure the temperature of the sample. Ideally, the sample temperature should be equal to the temperature standard of the Hydrometer, generally 60F. If temperature differences are unavoidable, correction tables can help to adjust your Hydrometer readings.
5. Take your reading at the point where the surface of the liquid crosses the Hydrometer.

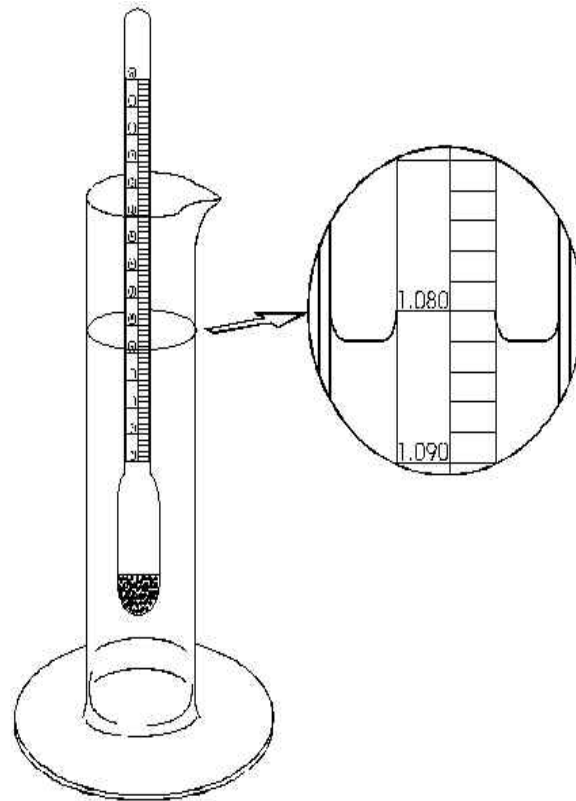

SG Reading	68°F	77°F (25C)	86°F (30C)	95°F (35C)	104°F (40C)
0.700	0.0005	0.0012	0.0019	0.0026	0.0033
0.800	0.0006	0.0014	0.0022	0.0030	0.0038
0.900	0.0006	0.0016	0.0026	0.0036	0.0046
1.000	0.0007	0.0018	0.0029	0.0040	0.0051
1.100	0.0008	0.0019	0.0030	0.0041	0.0052
1.200	0.0008	0.0020	0.0032	0.0044	0.0056

**EXAMPLE:** If your measured SG@68°F (20C) was 1.000 then the actual SG is  $1.000 + 0.0007 = 1.0007$