

INSTALLATION INSTRUCTIONS FOR RICHPAN 1040

1. GENERAL INFORMATION

RichPan 1040 is flexible polyvinyl chloride (PVC) membrane used under full mortar bed installations for concealed waterproofing. This sheet may be installed by a thin-bed method directly on properly prepared substrates per industry guidelines.

NOTES:

- a) RichPan is designed for full mortar bed installations.
- b) RichPan meets requirements the of IAPMO #3577.
- c) Do not use with direct thin-set tile method. Noble Company recommends using NobleSeal® TS for thin-set applications.
- d) Tile cannot be directly bonded to RichPan. A reinforced mortar bed is generally laid over RichPan. Tile can then be thin-set to the mortar bed. See TCNA guidelines.
- e) Install in strict compliance with these instructions, and comply with all applicable ANSI standards, TCNA recommendations and all applicable building and plumbing codes.
- f) For applications not detailed herein, contact Noble Company.

FIGURE 1. RICHPAN SYSTEM

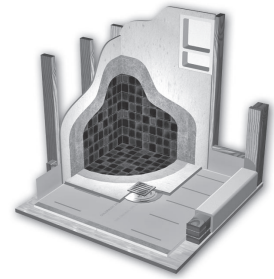

2. MATERIALS

- 2.1 **PRODUCT:** RichPan is a thin .040" (1.0 mm) PVC membrane for full mortar bed installations.
 - 2.1a **COMPOSITION:** RichPan is a flexible polyvinyl chloride (PVC) membrane.
- 2.2 **WATERPROOF SEALANT:** Use NobleSealant 150 to seam sheets, seal penetrations (i.e., pipes, wire), drains, and terminal edges. Seal preformed corners to sheet.
 - 2.3.1 **PVC SEAM CEMENT:** May be used instead of NobleSealant 150 to seam sheets of RichPan.
- 2.4 **PVC PREFORMED OUTSIDE/DAM CORNERS:** Use to flash curb/dam.
- 2.5 **TOOLS:** Normal tile setting tools plus scissors or utility knife, rubber hand roller, and linoleum roller. Application of NobleSealant 150 requires a commercial grade caulk gun.

3. PLANNING & LAYOUT

- 3.1 **MEMBRANE:** Quantity of RichPan sheet required should include waste, upturns and seams. Use preformed corners as necessary.
 - 3.1.a **SHEET DIMENSION:**
 - 4' x 50' (1.2m x 15.2m) roll = 200 sq. ft. (18.6m²)
 - 5' x 50' (1.5m x 15.2m) roll = 250 sq. ft. (22.8m²)
 - 6' x 50' (1.8m x 15.2m) roll = 300 sq. ft. (27.9m²)
- 3.2 **PVC PREFORMED OUTSIDE/DAM CORNERS:** Recommended even when not required.
- 3.3 **NOBLESEALANT 150:** A 10.3 oz. tube of NobleSealant 150 seams approximately 75 linear feet.
- 3.4 **PVC SEAM CEMENT:** One pint seams approximately 50 linear feet.

4. PREPARATION & PROCEDURES

- >>>>>**RECOMMENDED:** Test materials and method under job-site conditions to confirm suitability.
- 4.1 **INSPECTION:** The structural floor or substrate must be clean, smooth and free of holes, cracks and sharp projections. Nail heads should be driven flush or recessed.
 - 4.2 **BLOCKING:** Blocking between studs is recommended to support upturned membrane.

HINT: Notching the studs at each corner approximately 1/8" will provide space for folded RichPan corners and prevent backer board from bowing. If metal studs are used, the backer board can be "shimmed" slightly to provide space for the folded corners.
 - 4.3 **SUBSTRATES:** Substrate should be sloped per code requirements with no depressions where ponding could occur.

NOTE: Where drains are incorporated into the installation (e.g. showers, commercial kitchens, decks, etc.), the substrate must be sloped towards the drain.
 - 4.4 **DRAINS:** Drains must be equipped with proper clamping devices and weep holes. Inspect for warpage of clamping ring or drain body. Rotating clamping ring may improve seal. Replace drains warped over .040". When reusing existing drain, clean rust, caulk, mortar, etc., from face of clamping ring and matching surface on drain. Use NobleSealant 150 to form watertight seal between RichPan and the drain body.
 - 4.5 **INSTALLER:** Must be familiar with Noble Company's current written instructions, TCNA Handbook recommendations and ANSI A108 and A118 standards. Contractor must be experienced with installation procedures for Noble Company products or be instructed by a Noble Company representative prior to commencing work.

5. INSTALLATION PROCEDURES

- 5.1 **PAN:** Line the area with RichPan. Allow for upturn when cutting sheet.

NOTE: Rolls of RichPan are marked on each side with black lines at approximately 6" intervals. These marks are intended to be used as guidelines, not accurate measurements.
- 5.2 **UPTURNS:** The upturn should be 3" above the finished dam or floodplane as specified or required by code. Membrane should be flashed behind the backer board.
- 5.3 **FOLDED CORNERS:** Turn the sheet up on all sides using folded corners (see Figure 3), or use preformed inside corners as needed.
- 5.4 **FASTEN:** Secure the liner to the backing or studs with nails or staples in top 1" of flashed membrane. Install upturn at dam over the top and fasten on outside face. Where metal studs are used and no backup material is provided, use sheet metal screws and washers. Fold the material over 1" at the top to give extra strength and fasten it to the studs. Where walls are concrete or block, use masonry nails, screws with washers or NobleSealant 150. Follow directions on label.
- 5.5 **PVC PREFORMED OUTSIDE/DAM CORNERS:** Protects against water leakage at the junction of the shower opening and the dam. Recommended even when not required. To install corners, use NobleSealant 150 and follow seaming and joining procedures for NobleSealant 150.
- 5.6 **DRAINS:** Press firmly on the RichPan using drain body as a cutting template to cut the opening.

CAUTION: When cutting bolt holes, do not cut beyond outside perimeter of clamping area (see Figure 2). Snug bolts evenly and then tighten firmly to make a watertight seal. Apply a bead of NobleSealant 150 under the sheet over the clamping ring drain body.

5. INSTALLATION PROCEDURES (con't.)

5.7 PENETRATIONS: If it becomes necessary to penetrate the membrane below the waterline or in any other critical area, use a piece of RichPan 3" larger (all sides) than damaged area and secure in place.

5.8 SEAMING AND JOINING PROCEDURES: When the area to be waterproofed is wider than the width of a sheet, sheets may be seamed (joined) using NobleSealant 150 or PVC seam cement. Both methods provide permanent, waterproof seams.

CAUTION: Bonding area must be dry, clean and free of dust, dirt, oil and grease.

5.8.1 NOBLESEALANT 150 (see instructions on tube):

- Lay out sheets to overlap approximately 2" and mark.
- Apply 1/8" bead (minimum) of sealant 1/4" from edge on first sheet (spread rate 150 l.f./tube).
- Apply second bead 3/4" from edge on first sheet.
- Overlap first sheet and flatten beads with hand roller, trowel or putty knife.

5.9 TESTING: Test installation by filling pan with water. Inspect for leakage. If leaking is detected, first re-tighten clamping ring, then inspect ring to be certain it mates with the drain body and is not warped. If defective, replace. It may be possible to seal by welding a second layer of RichPan in area of drain body and/or sealing with NobleSealant 150. Repeat testing until no leaks can be detected.

TIP: To protect liner from damage, water may be left in pan.

6. WARRANTY

RichPan is guaranteed for five years by Noble Company against failure caused by rotting, cracking and microorganism deterioration when properly installed in concealed construction waterproofing and applications for which its use is recommended by Noble Company. This warranty is limited to replacement of defective material and freight charges to destination only. There are no other express or implied warranties, and this warranty is in lieu of any other warranty, including, but not limited to, implied warranties of merchantability and fitness for purpose. Noble Company is not responsible for consequential damages. The remedy of the purchaser set forth herein is exclusive.

NOTE: RICHPAN MUST BE INSTALED IN STRICT COMPLIANCE WITH THESE INSTRUCTIONS, APPLICABLE ANSI STANDARDS, TCNA RECOMMENDATIONS AND ALL APPLICABLE BUILDING CODES.

These suggestions and data are based on information Noble Company believes to be reliable. Users should verify by tests that RichPan, as well as these installation methods, are suitable with the products being used in their application. Since specific use, materials and handling are not controlled by Noble Company, this warranty is limited to the replacement of defective Noble Company products. Noble Company disclaims any responsibility for (a) warranties of merchantability and fitness for purpose; (b) verbal recommendations of its representatives; and (c) consequential damages.

7. CAD DETAILS

FIGURE 1. TYPICAL SHOWER

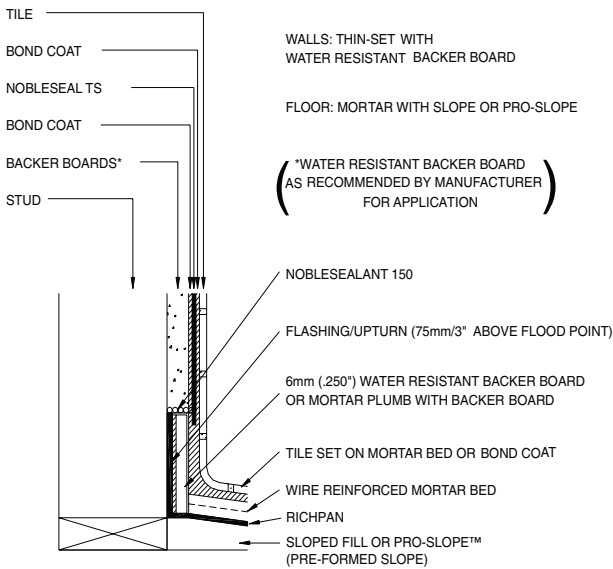
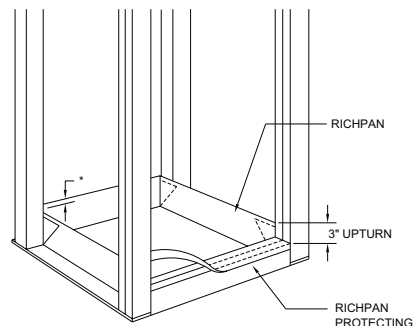

FIGURE 2. SHOWER PAN



*NAILS USED TO SECURE RICH PAN TO BLOCKING/JOISTS SHOULD BE IN UPPER 1/2" OF UPTURNS.

FIGURE 3. DRAIN

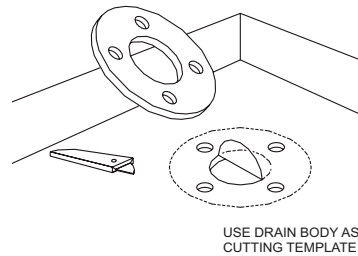
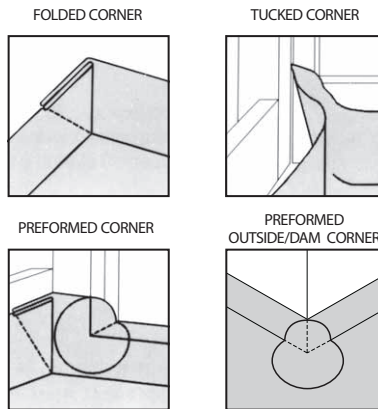

FIGURE 4. CORNERS



Form RP Inst 08/09
Supersedes 04/09