

NobleFlex[®]

Drain Flashing



Allows standard clamping ring drains to be used with thin-set or full mortar bed waterproofing membranes.



U.S. Patent No. 7,632,401

- **Made from Chlorinated Polyethylene (CPE) with non-woven fiber laminated to both sides**
- **Available in 2 depths**
- 3/4" and 1-1/2"
- **Provides smooth transition of the membrane to a clamping ring drain**
- **Ideal for thin-set waterproofing membranes (ANSI A 118.10) or full mortar bed membranes when the drain is set too low**
- **Alternative to "integrated bonding flange" drains**
- **Easy to install**

Dimensions:



NobleFlex 1-1/2" Deep Drain Flashing
Dimension A: 1-1/2"
Dimension B: 8-1/2"
Dimension C: 10-1/5"



NobleFlex 3/4" Deep Drain Flashing
Dimension A: 3/4"
Dimension B: 8-1/2"
Dimension C: 9-2/5"

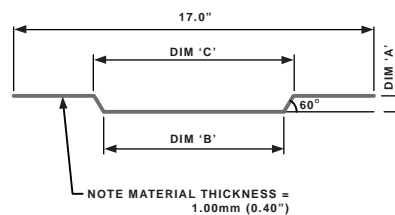
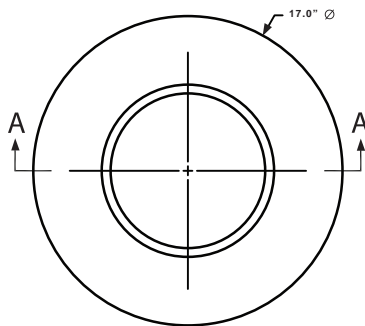

Simple Solutions... Proven Performance

NobleFlex® Drain Flashing Installation Instructions

1.0 Materials

NobleFlex Drain Flashing (3/4" or 1-1/2" deep)
NobleSealant 150
Positive Weep Protector™ (Note: Only for use with 1-1/2" NobleFlex Drain Flashings)
Waterproofing Membrane (i.e. NobleSeal® TS, Chloraloy®, etc.)
Optional: NobleFlex Drain Flashing Tool (3/4" or 1-1/2" deep)

2.0 Preparatory Work

Determine the proper Drain Flashing depth (3/4" or 1-1/2") needed to adapt the waterproofing membrane down to the clamping ring drain. Verify that the strainer can be adjusted (high or low) to the finished flooring elevation.

If NobleFlex Drain Flashing Tool is used:

Remove strainer, clamping ring, and retaining bolts.
Center tool on drain body.
Hold tool down firmly and pack mortar bed around tool. Install sloped bed from the tool to the perimeter of shower.
Remove tool.

If NobleFlex Drain Flashing Tool is not used:

Install sloped mortar bed to perimeter of the shower making sure to shape mortar bed to support NobleFlex Drain Flashing.

3.0 Installing Drain Flashing to Clamping Ring Drain

Remove strainer and clamping ring.

Insure that Drain Flashing is supported on underside by properly tapered mortar bed. Add or remove mortar as necessary. Trace drain hole opening and bolt holes onto flashing. Carefully cut out inside drain opening and openings for clamping ring bolts. Apply a bead of NobleSealant 150 on the lower drain body.

Bond Drain Flashing to substrate with latex modified thin-set or NobleBond EXT. Embed Flashing into bond coat.

Install the Drain Flashing by pressing the clamping ring bolts through openings in the Flashing.

Reset clamping ring and firmly tighten bolts. Follow manufacturer's instructions.

Protect weep holes from clogging.

Replace strainer and adjust to proper height for tile.

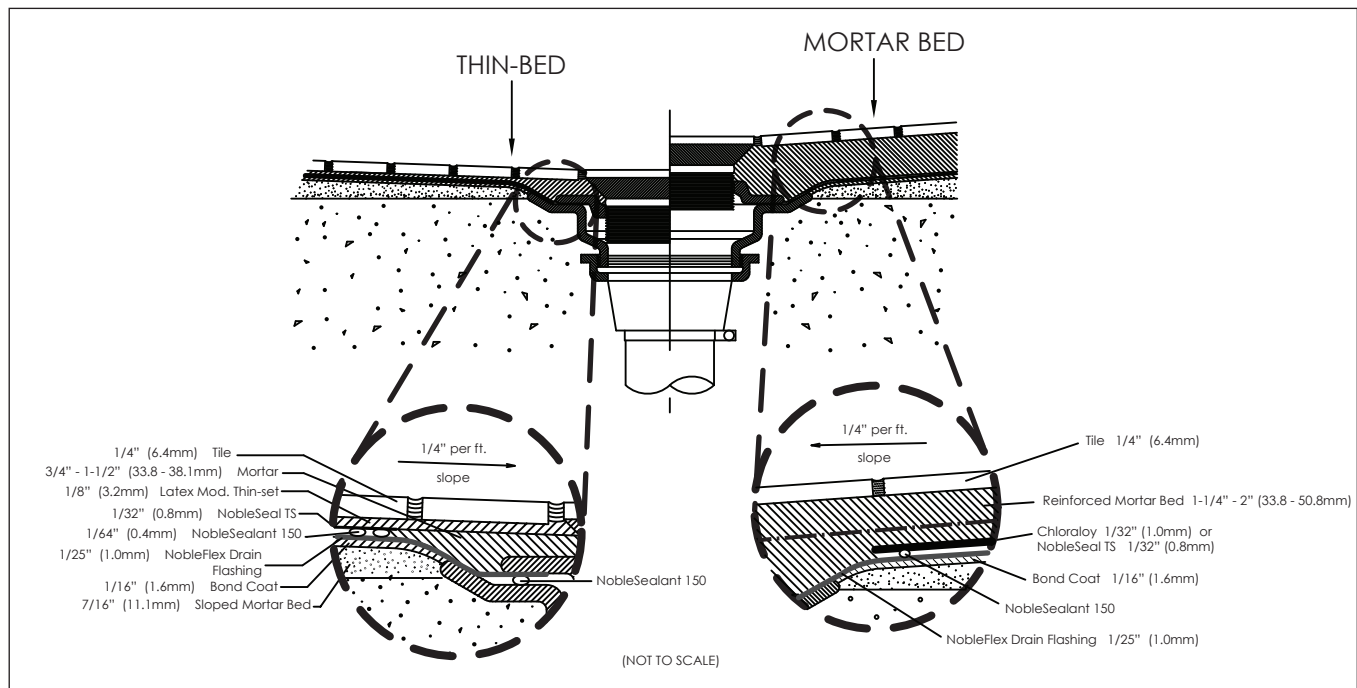

4.0 Installation of Waterproof Membrane

Install waterproof membrane according to manufacturer's instructions.

5.0 Seaming Waterproof Membrane to Drain Flashing

Drain Flashing and waterproof membrane surfaces must be clean and dry.

NOTE: Fabric does not need to be removed. Do not solvent weld materials together.

Waterproof membrane should overlap the Drain Flashing a minimum of 2".

Apply a 3/16" bead of NobleSealant 150 a 1/2" from the edge of the Drain Flashing.

Overlap sheet membrane on top of Drain Flashing and embed with roller.

6.0 Flood Test

Test for leaks per local code requirements.

7.0 Completing the Slope

Fill depression in Drain Flashing with mortar to required plane.

Follow appropriate industry standards.

U.S. Patent No. 7,632,401



P.O. Box 350 • Grand Haven, MI 49417-0350 • Phone: 800-878-5788 • 231-799-8000 • Fax: 231-799-8850 • www.noblecompany.com
® Registered Trademark of Noble Company, Grand Haven, MI.

Form #NF DF PD INST 04/11
Supersedes #NF DF PD 06/08